



Ducto 150

Ordering Information

Part Number	Description
BLADUCTO150	150mm Inline Axial Fan

Application

- Inline axial fan
- Designed for the extraction of air from bathrooms, kitchens, ensuites, toilets and laundries. Other applications include supply air fans for air conditioning units and rangehood booster fans.

Features:

- Inline mounted
- Silent impeller
- Easy maintenance
- Designed for longer continuous use
- Ball bearing motor

Wiring

- Lead & plug fitted to the fan

Overall and installation dimensions

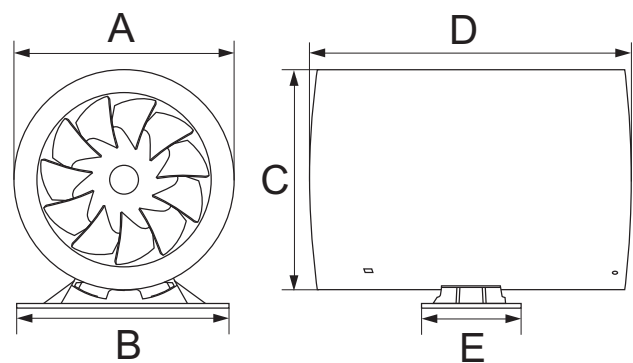

Model Number	Dimensions mm				
	∅A	B	C	D	E
BLADUCTO150	148	190	148	182	52

Specifications

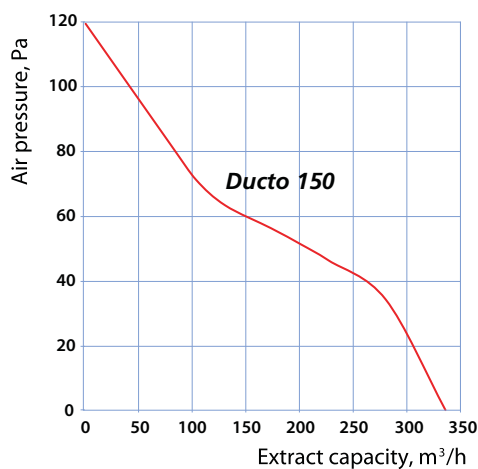

Parameters	Ducto 150
Voltage, V	220-240
Power, W	22
Extract capacity, m³/h	335
Noise level, dBA 3m	38
r.p.m	2000

Safety regulations

