



Model

CENTRO 200 W1 - CENTRIFUGAL FAN

Description

200mm inline centrifugal duct fan, 1.2m power cord

Application

Kitchens / Commercial / Apartments / Carparks / Industrial

Technical specification

Voltage [V/50 Hz]	220-240 AC
Power [W]	107
Current [A]	0.47
Extract capacity [m ³ /h]	780
Noise level 3m [dBA]	48
r.p.m.	2660
Installation type	Inline duct
Installation position	Any
DN (diameter nominal) [mm]	200
Air flow temperature [°C]	-25 - +55
Index of protection	IP X4
Internal thermal protection	Manual reset
Colour	Blauberg grey
Casing material	ABS plastic
Warranty	5 years

Characteristic curve

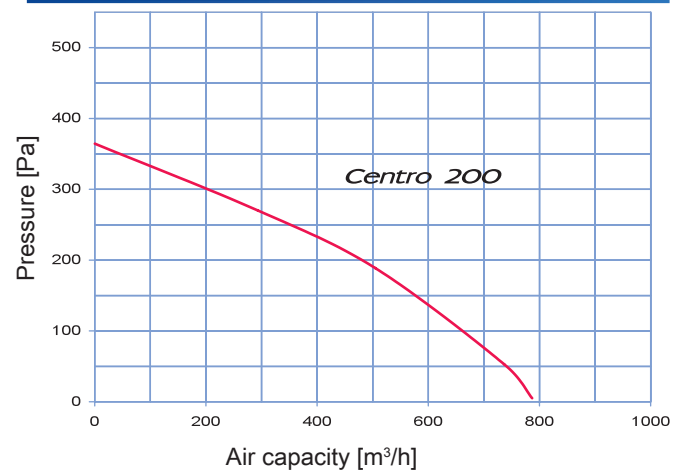

Dimensions [mm]

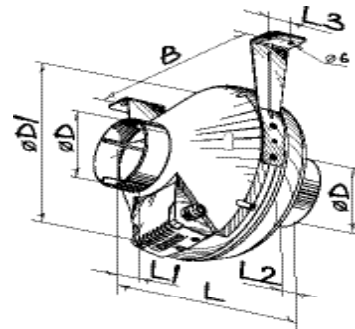

Type	Dimensions [mm]				
	d	d1	l	b	l1, 2, 3
Centro 200 W1	200	340	276	340	30

Sound power levels

Sound pressure level	Octave-frequency band [Hz]								
	Gen	63	125	250	500	1000	2000	4000	8000
LwA to inlet, dBA	76	47	65	65	70	63	61	61	49
LwA to outlet, dBA	81	53	66	71	73	65	68	63	51
LwA to environment, dBA	64	45	62	59	48	34	26	45	39

Ventilation Solutions Australia (VSA) is not responsible for mistakes or printing errors and retain the right to make technical modifications without giving prior notice.

Email: info@ventilationsolutions.com.au
Phone: 1300 998 326

